



R10T: TABLETOP DOUGH ROUNDER

SERIES: FORZA FORNI APPLIANCES



REFERENCE INVOICE #:

THE PREFERRED DOUGH ROUNDER

The Friulco R10T is a table top dough rounder designed to create perfect dough balls effortlessly. The ideal round and closed ball shape is achieved without any change or adjustment in settings, no matter the size or hydration of the dough portion. The structure of the machine is fabricated in thick AISI 300 & 400 series stainless steel, with anodized aluminum castings. The dough basket is coated in Teflon®, ensuring smooth motion of dough through its circular path. Designed to be easy for anyone to disassemble and clean, the R10T is manufactured in Italy according to the highest sanitary and safety norms. For more information on this product, please visit www.forzaforni.com.

- Designed for use on any tabletop or flat surface and can be used for pizza as well as bread dough.
- Teflon® coating on the rounding basket reduces the likelihood of high-hydration dough sticking to the basket walls.
- Does not need to be adjusted for dough weight - just drop the dough portion in the basket

DOUGH SPECIFICATIONS

Hourly Dough Production	Individual Dough Portion Weight
88 - 660 lbs	2.5 - 42 Oz

DIMENSIONS

Weight	Width	Depth	Height
135 lbs	33.6"	28.4"	15.0"

ELECTRICAL REQUIREMENTS

Phase	Voltage	Current	Power
1 Phase	115 V / 60 Hz	4.8 A	370 W



Supplied with a standard NEMA 5-15P plug

DIMENSIONAL DRAWING

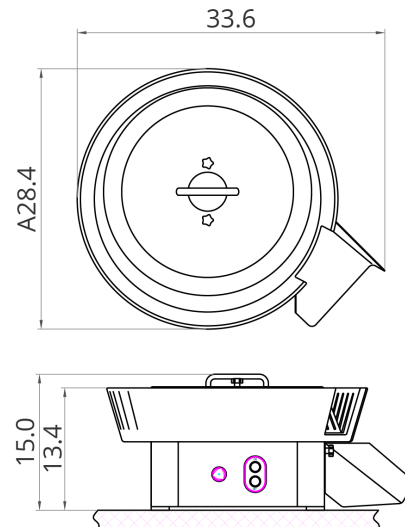

1 year limited warranty on parts. See warranty document for details.

FORZA FORNI
601 N Main St, Brewster, NY 10509
Email: info@forzaforni.com
www.forzaforni.com

844-OVEN-INC (844-683-6462)
Toll-free in USA
(Hablamos Español,
Falamos Português)

Listed to: ANSI/UL 763 &
CAN/CSA-C22.2 No. 195
Commercial Powered Food
Preparation Equipment



DOC#: R10T-11-19

REVISED FALL 2019. As products continue to improve, spec sheets may change without notice. Please call Forza Forni for the latest specification sheet and for further details.

MADE IN ITALY